

# R05-A

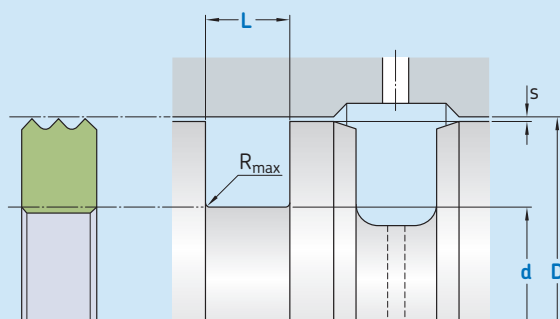

Ordering dimensions in **blue**

Surface roughness	$R_{tmax}$	$R_a$
<b>Sliding surface</b>	$\leq 2,5 \mu\text{m}$	$0,1-0,5 \mu\text{m}$
<b>Bottom of groove</b>	$\leq 6,3 \mu\text{m}$	$\leq 1,6 \mu\text{m}$
<b>Groove face</b>	$\leq 15 \mu\text{m}$	$\leq 3 \mu\text{m}$

Hardness: Min 45 HRC (55 HRC recommended), hardened depth  $> 0,3 \text{ mm}$ .  
Bearing area: 50–95% and a cutting depth of  $0,5 R_z$  based on  $C_{ref} = 0\%$

## Standard dimensions

$D^*$		$d$	$L$	$R_{max}$	$s$
over	incl.	$h8$	$+ 0,2$		
mm					
<b>13</b>	<b>30</b>	$D - 8$	4,5	0,2	H9/e8
<b>30</b>	<b>46</b>	$D - 10$	5,6	0,2	H9/e8
<b>46</b>	<b>68</b>	$D - 12$	5,6	0,2	H9/e8
<b>68</b>	<b>100</b>	$D - 15$	7,7	0,2	H7/f7
<b>100</b>	<b>160</b>	$D - 20$	9,2	0,2	H7/f7
<b>160</b>	<b>225</b>	$D - 25$	11,3	0,2	H7/f7
<b>225</b>	<b>330</b>	$D - 30$	13,5	0,2	H7/f7
<b>330</b>		$D - 40$	18,5	0,2	H7/f7

\* Tolerance area counter surface  $\leq 68 \text{ mm} \rightarrow H9$ ,  $> 68 \text{ mm} \rightarrow H7$

## Ordering example

Profile  
 $d \times D \times L$  [mm]  
Sealing material

Rotary seal R05-A  
100 x 120 x 9,2  
ECOPUR



## Operating parameters

Material Seal	Temperature		Speed <sup>1)</sup>	Pressure <sup>2)</sup>
	from	to	max	max
–	°C		m/s	bar (MPa)
■ ECOPUR	–30		0,2	
■ H-ECOPUR	–20	+110		160 (16)
■ S-ECOPUR			0,3	
■ T-ECOPUR	–50			
■ SKF Ecorubber-1	–30	+100		
■ SKF Ecorubber-2	–20	+200	0,2	
■ SKF Ecorubber-3	–50	+150		100 (10)
■ SKF Ecorubber-H	–25			
■ SKF Ecoflas	–10	+200		

IMPORTANT NOTE: The stated operating conditions represent general indications. It is recommended not to use all maximum values simultaneously.

<sup>1)</sup> Surface speed limit values are valid only in the presence of a lubrication film.

<sup>2)</sup> Pressure ratings depend on the size of the extrusion gap.

© ECOPUR and SKF are registered trademarks of the SKF Group

© SKF Group 2012

The contents of this publication are the copyright of the publisher and may not be reproduced (even extracts) unless prior written permission is granted. Every care has been taken to ensure the accuracy of the information contained in this publication but no liability can be accepted for any loss or damage whether direct, indirect or consequential arising out of the use of the information contained herein.

PUB SE/P8 11873 EN · March 2012

